

**Field-mounted Two-wire Signal Conditioners**

**2-WIRE UNIVERSAL TEMPERATURE TRANSMITTER  
(HART® communication, intrinsically safe/explosion-proof)**

MODEL

**FRC**

**MODEL & SUFFIX CODE SELECTION**

FRC□□□□A

MODEL \_\_\_\_\_

ENCLOSURE \_\_\_\_\_

0 : None \*1  
1 : Diecast aluminium  
2 : Stainless steel casting

SAFETY APPROVAL \_\_\_\_\_

A : None  
C : CENELEC flameproof (ATEX)  
E : CENELEC intrinsically safe (ATEX)

LCD DISPLAY \_\_\_\_\_

0 : Without  
1 : With

WIRING CONDUIT \*2 \_\_\_\_\_

0 : None  
1 : 1/2 NPT  
2 : M20 × 1.5  
3 : PG 13.5

\*1. Choose the suffix code 0 for "Wiring Conduit"  
\*2. Confirm selectable combinations of approval and wiring conduit types in the table below.

**SELECTABLE WIRING CONDUITS SPECIFIC TO EACH APPROVAL**  
'N' marked combinations are not selectable.

CONDUIT \ APPROVAL	A	C	E
0	Y	N	Y
1	Y	Y	Y
2	Y	Y	Y
3	Y	N	Y

**RELATED PRODUCTS**

- PC Configurator Software
  - HART modem\*  
MACTek VIATOR RS232 HART® IF recommended
  - Hand-held communicator\*
- \* Consult HART® Communication Foundation (HCF) web site : [www.hartcomm.org](http://www.hartcomm.org)

**GENERAL SPECIFICATIONS**

**Degree of protection :** NEMA 4X, IP65  
**Wiring conduit :** See "Model & Suffix Code".  
**Electrical connection :** M3.5 screw terminals (torque 0.8 N-m)  
**Materials**  
**Transmitter housing :** Flame-resistant resin (black)  
**Screw terminals :** Nickel-plated brass  
**Enclosure :**  
Diecast aluminium standard (polyurethane coated)  
or stainless steel casting (equivalent to type 316,  
epoxy resin coated).

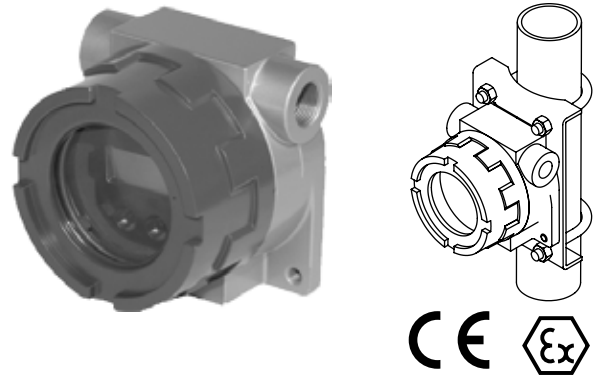

**Functions & Features**

- Universal input: mV, V, T/C and RTD
- High accuracy
- HART communication
- Intrinsically safe and explosion-proof approval
- CE marking (conforms to ATEX and EMC)
- Optional stainless steel enclosure
- Programming via hand-held communicator or via PC
- A wide variety of T/C and RTD types
- Self diagnostics
- Input-output isolated

**Enclosure color :**

- Body :** Silver
- Cover :** Blue (equivalent to Munsell GPB3.5/10.5)  
Silver for stainless steel

**Mounting bracket assembly :**

Stainless steel 304

**Applicable pipe :**

1" 1/2 min.; 2" max.

**Isolation :**

Input to output to outdoor enclosure

**User-configurable parameters :**

- Input sensor type
- Number of wires (RTD)
- Input range
- Output range (via HART® only)
- Output calibration
- HART communication mode
- HART network mode

**Burnout (T/C & RTD) :**

Upscale, downscale or no burnout selectable (standard: upscale);  
Also detects wire breakdown and overrange input exceeding the electrical design limit for DC input.

**Cold junction compensation (T/C) :**

CJC sensor incorporated

**Damping time :**

0 to 30 sec. (standard : 0)

## LCD DISPLAY (option)

**Features:**

- Indicates and sets input signal, engineering unit and transmitter status.
- Removable while the module is powered.

**Display size :** 36 × 20 mm (1.41" × 0.79")

**Characters :**

**Color :** Black  
**Format :** 2 rows of 5 alphanumeric characters;  
Top: 7.4 mm high  
Bottom: 6.5 mm high  
6 status characters, 1.9 mm high

**Display range :**

-99999 to 99999

**Decimal point :**

Top row only; positioned between two characters

**Read rate :** 150 msec.

**Back light :** None

## HART® COMMUNICATION

**Protocol :**

HART® communication protocol

**HART® address range :**

0 – 15 (standard: 0)

**Transmission speed :** 1200 bps

**Digital current :**

Approx. 1mA p-p when communicating

**Character format :**

1 Start Bit, 8 Data Bits, 1 Odd Parity Bit, 1 Stop Bit

**Distance :**

1.5 kilometers (0.9 mile)

**HART® communication mode :**

Master-Slave Mode and Burst Mode (standard: Master-Slave)

**HART® network mode :**

Point-to-Point Mode and Multi-drop Mode; automatically set to Multi-drop Mode when the address is set to other than 0.

## INPUT

The input is factory set for use with 3-wire Pt 100, 0 to 100°C. See Table 1 for the available input type, the minimum span and the maximum range.

### ■ DC mV & V

**Input resistance :** 1MΩ minimum

### ■ THERMOCOUPLE

**Input resistance :** 1MΩ minimum

**Burnout sensing :** 130nA ±10%

### ■ RTD (2-wire, 3-wire or 4-wire)

**Input resistance :** 1MΩ minimum

**Excitation :** 0.2mA ±10%

**Allowable leadwire resistance :** Max. 20Ω per wire

## OUTPUT

**Output range :** 4 – 20mA DC

**Zero adjustment :** 3.8 – 7.2mA (standard: 4mA)

**Span adjustment :** 12.8 – 17.6mA (standard: 16mA)

**Operational range :** 3.8 – 21.6mA

**Load resistance vs. supply voltage:**

Load Resistance (Ω) =  $\frac{\text{Supply Voltage (V)} - 12 \text{ (V)}}{0.024 \text{ (A)}}$   
(including leadwire resistance)

## INSTALLATION

**Supply voltage :**

12 – 42V DC (non-approved)

12 – 28V DC (approved)

**Operating temperature:**

-40 to +85°C Electronics

(See Safety Parameters for use in a hazardous location.)

-30 to +80°C Display (full visibility)

**Operating humidity:**

0 to 95% RH (non-condensing)

**Dimensions :**

See External Dimensions.

**Weight :**

**FRC0 :** Approx. 150 g including the LCD

**FRC1 :** Approx. 1.3 kg

**FRC2 :** Approx. 4.0 kg

## PERFORMANCE

**Accuracy :**

See Table 1 and "Explanation of Terms"

**Cold junction compensation error :** ≤ ±0.5°C

**Temperature coefficient :**

±0.015%/°C of max. range at -5 to +55°C

**T/C and DC mV :** ±0.015%/°C at -40 to +85°C

**Pt 100, span ≥ 100°C :** ±0.015%/°C at -40 to +55°C

±0.03%/°C at 55 to 85°C

**Start-up time :**

Approx. 8 seconds

**Response time :**

1 second (0 – 63%) with damping time set to 0 and when not communicating via HART®.

**Supply voltage effect :**

±0.003% x [Output Span] / 1V

**Insulation resistance :**

≥100MΩ with 500V DC (input to output)

**Dielectric strength :**

1500V AC /1 minute (input to output to outdoor enclosure)

## STANDARDS & APPROVALS

**CE conformity:** ATEX Directive (94/9/EC)

Ex ia EN 50020

Ex d EN 60079-1

EMC Directive (2004/108/EC)

EMI EN 61000-6-4

EMS EN 61000-6-2

**Safety approval**

CENELEC: Intrinsically safe (ATEX)

⊕ II 1G, Ex ia IIC; T4, T5 and T6

(EN 50020 : 2002)

CENELEC: Flameproof (ATEX) \*\*

⊕ II 2G, Ex d IIC; T4, T5 and T6

(EN 60079-1 : 2007)

\*\*FRC1 or FRC2

## SAFETY PARAMETERS

**Operating temperature for CENELEC (ATEX):**

T4 -40 to +80°C

T5 -40 to +65°C

T6 -40 to +50°C

**Ex-data:**

Ui 30V DC

Uo 6.4V DC

Ii 96mA DC

Io 30mA DC

Pi 0.72W

Po 48mW

Ci 0 μF

Co 20 μF

Li 0 mH

Lo 10 mH

## EXPLANATIONS OF TERMS

### ■ ACCURACY

This transmitter's accuracy is theoretically defined as the addition of A/D and D/A conversion errors:

$$\text{Accuracy} = \text{A/D Conversion Error} + \text{D/A Conversion Error}$$

The A/D conversion error means that measured as HART signal which is A/D converted from the analog input signal.

The D/A conversion error of this transmitter is relatively very small so that it does not really affect the unit's overall performance.

The "Accuracies" given in Table 1 therefore equals the A/D conversion error.

The temperature drift (coefficient) or the cold junction compensation error is not included in the "Accuracy."

### ■ CALCULATION EXAMPLES OF OVERALL ACCURACY IN %

#### • DC Voltage

1) 0 – 200mV

$$\begin{aligned} \text{Absolute value accuracy (Table 1): } & 40\mu\text{V} \\ 40\mu\text{V} / 200000\mu\text{V} \times 100 & = 0.02 \% < 0.1\% \end{aligned}$$

⇒ Overall accuracy = ±0.1% of span

2) 0 – 4mV

$$\begin{aligned} \text{Absolute value accuracy (Table 1): } & 10\mu\text{V} \\ 10\mu\text{V} / 4000\mu\text{V} \times 100 & = 0.25 \% > 0.1\% \end{aligned}$$

⇒ Overall accuracy = ±0.25% of span

#### • Thermocouple

1) K thermocouple, 0 – 1000°C

$$\begin{aligned} \text{Absolute value accuracy (Table 1): } & 0.25^\circ\text{C} \\ 0.1\% \times 1000^\circ\text{C} & = 1^\circ\text{C} > 0.25^\circ\text{C} \end{aligned}$$

$$\begin{aligned} \text{CJC error (0.5}^\circ\text{C) added: } & 1 + 0.5 = 1.5^\circ\text{C} \\ 1.5^\circ\text{C} / 1000^\circ\text{C} \times 100 & = 0.15 \% \end{aligned}$$

⇒ Overall accuracy including CJC error = ±0.15% of span

2) K thermocouple, 50 – 150°C

$$\begin{aligned} \text{Absolute value accuracy (Table 1): } & 0.25^\circ\text{C} \\ 0.1\% \times (150 - 50)^\circ\text{C} & = 0.1^\circ\text{C} < 0.25^\circ\text{C} \end{aligned}$$

$$\begin{aligned} \text{CJC error (0.5}^\circ\text{C) added: } & 0.25 + 0.5 = 0.75^\circ\text{C} \\ 0.75^\circ\text{C} / (150 - 50)^\circ\text{C} \times 100 & = 0.75 \% \end{aligned}$$

⇒ Overall accuracy including CJC error = ±0.75% of span

#### • RTD

1) Pt 100, -200 – 800°C

$$\begin{aligned} \text{Absolute value accuracy (Table 1): } & 0.15^\circ\text{C} \\ 0.15^\circ\text{C} / (800 - (-200))^\circ\text{C} \times 100 & = 0.015 \% < 0.1\% \end{aligned}$$

⇒ Overall accuracy = ±0.1% of span

2) Pt 100, 0 – 100°C

$$\begin{aligned} \text{Absolute value accuracy (Table 1): } & 0.15^\circ\text{C} \\ 0.15^\circ\text{C} / 100^\circ\text{C} \times 100 & = 0.15 \% > 0.1\% \end{aligned}$$

⇒ Overall accuracy = ±0.15% of span

## INPUT TYPE, RANGE & ACCURACY

### ■ INPUT TYPE, RANGE & ACCURACY

TABLE 1

INPUT TYPE	MIN. SPAN	MAXIMUM RANGE	ACCURACY					
DC mV & V	4mV	-50 to +1000mV	±0.1% or ±10μV, whichever is greater (F.S. input ≤50mV) ±0.1% or ±40μV, whichever is greater (F.S. input ≤200mV) ±0.1% or ±60μV, whichever is greater (F.S. input ≤500mV) ±0.1% or ±80μV, whichever is greater (F.S. input >500mV)					
Thermocouple	°C				°F			
	MIN. SPAN	MAXIMUM RANGE	CONFORMANCE RANGE	ACCURACY *1	MIN. SPAN	MAXIMUM RANGE	CONFORMANCE RANGE	ACCURACY *1
	(PR)	0 to 1760	0 to 1760	±1.00	36	32 to 3200	32 to 3200	±1.80
	K (CA)	-270 to +1370	-150 to +1370	±0.25	36	-454 to +2498	-238 to +2498	±0.45
	E (CRC)	-270 to +1000	-170 to +1000	±0.20	36	-454 to +1832	-274 to +1832	±0.36
	J (IC)	-210 to +1200	-180 to +1200	±0.25	36	-346 to +2192	-292 to +2192	±0.45
	T (CC)	-270 to +400	-170 to +400	±0.25	36	-454 to +752	-274 to +752	±0.45
	B (RH)	100 to 1820	400 to 1760	±0.75	36	212 to 3308	752 to 3200	±1.35
	R	-50 to +1760	200 to 1760	±0.50	36	-58 to 3200	392 to 3200	±0.90
	S	-50 to +1760	0 to 1760	±0.50	36	-58 to +3200	32 to 3200	±0.90
	W	0 to 2315	0 to 2315	±0.25	36	32 to 4199	32 to 4199	±0.45
	N	-270 to +1300	-130 to +1300	±0.30	36	-454 to +2372	-202 to +2372	±0.54
	U	-200 to +600	-200 to +600	±0.20	36	-328 to +1112	-328 to +1112	±0.36
	L	-200 to +900	-200 to +900	±0.25	36	-328 to +1652	-328 to +1652	±0.45
P (Platinel II)	0 to 1395	0 to 1395	±0.25	36	32 to 2543	32 to 2543	±0.45	
RTD	°C				°F			
	MIN. SPAN	MAXIMUM RANGE	ACCURACY *2	MIN. SPAN	MAXIMUM RANGE	ACCURACY *2		
Pt 100 (JIS '97, IEC)	20	-200 to +850	±0.15	36	-328 to +1562	±0.27		

\*1. [Accuracy or ±0.1% of span, whichever is greater] + Cold Junction Compensation Error 0.5°C

\*2. Or ±0.1% of span, whichever is greater. (For 2- or 3-wire RTD, the value is valid by the sensor calibration after the wiring is done.)

# SCHEMATIC CIRCUITRY & CONNECTION DIAGRAM

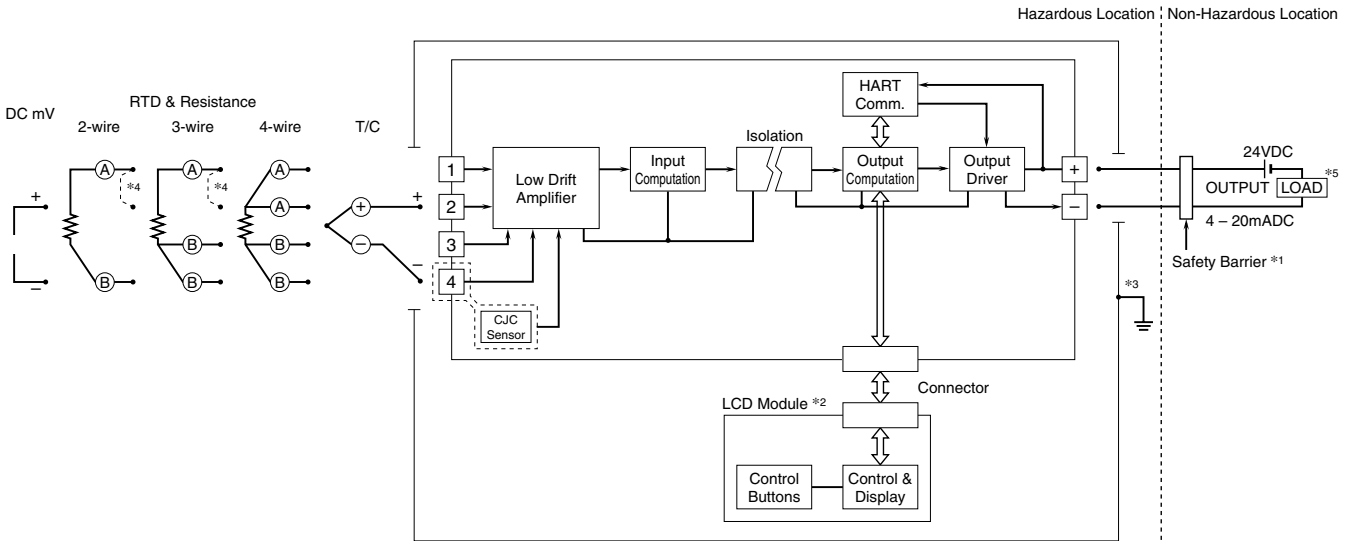

- \*1. A safety barrier must be installed for the intrinsic safety. The safety barrier must meet the Ex-data of this unit and must be approved for the hazardous location.
- \*2. Optional
- \*3. Be sure to earth the unit's enclosure to meet the intrinsic safe or explosion-proof (flameproof) requirements.
- \*4. Close across the terminals 1 & 2 for 2-wire/3-wire RTD input.
- \*5. Limited to 250 – 1100Ω for HART communication.

# EXTERNAL DIMENSIONS & MOUNTING REQUIREMENTS unit: mm (inch)

## ■ FRC0

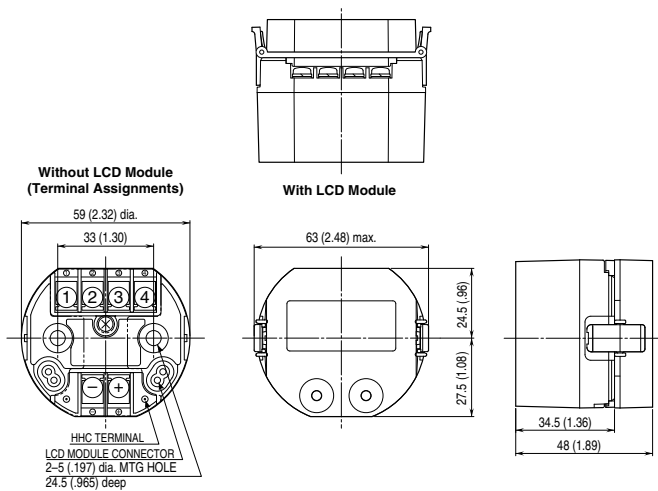

## ■ FRC1, FRC2

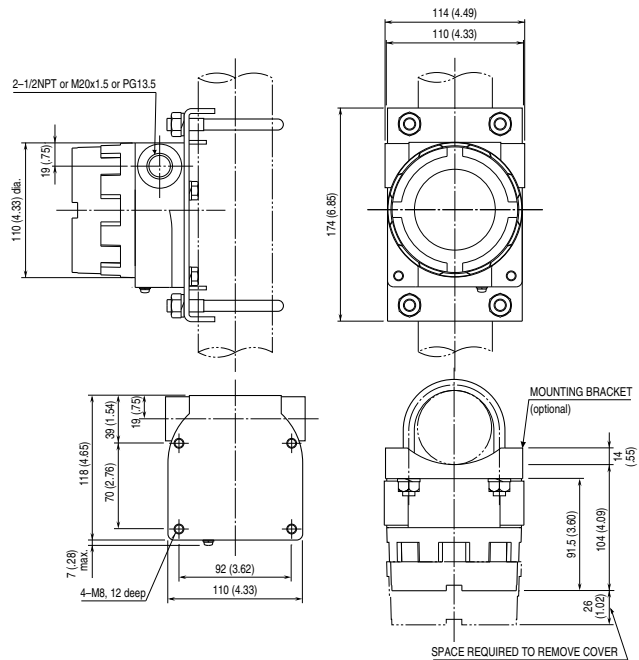

# Fuji Electric France S.A.S.

46, Rue Georges Besse - Z I du Brézet  
 63 039 Clermont-Ferrand cedex 2 — FRANCE  
 France : Tél. 04 73 98 26 98 - Fax 04 73 98 26 99  
 International : Tél. (33) 4 7398 2698 - Fax. (33) 4 7398 2699  
 E-mail : sales.dpt@fujielectric.fr

Fuji Electric can accept no responsibility for possible errors in catalogues, brochures and other printed material. Fuji Electric reserves the right to alter its products without notice. This also applies to products already on order provided that such alterations can be made without subsequential changes being necessary in specifications already agreed. All trademarks in this material are property of the respective companies. All rights reserved.