

PXF4 is an extremely compact temperature controller which has 48 x 48 mm front panel with a large, white LCD and 58-mm depth behind panel.

Developed as a successor to the standard model PXR, PXF4 features fast sampling speed (50 ms) equal to PXH, highly accurate input indication, and universal input, in addition to various functions of PXG, while achieving a competitive price.

Equipped with multiple input/output and sophisticated control functions, PXF4 serves as a suitable temperature controller for a wide range of use.



## FEATURES

- Enhanced control performance which makes PXF suitable for a wide range of application
  - Fast sampling speed of 50 ms (cf. PXH: 50 ms, PXR: 500 ms)
  - Improved input indication accuracy  
For example: indication accuracy when measuring around 0.0°C by using type K thermocouple of which measuring range 0.0 to 400.0°C: ±1.1°C (cf. PXR: ±3.1°C)
  - Freely configurable control cycle (100 ms to 99 s)
  - Control method selectable among 7 types (ON/OFF control, PID control, fuzzy PID control, self-tuning control, PID2 control, 2-degrees-of-freedom PID control, motorized valve control)
- Any type of input can be accepted
  - Universal input is supported (thermocouple, RTD, voltage, current)
  - Control output is selectable among 4 types (Relay contact, SSR drive, current linear, voltage linear)  
The following optional functions can be incorporated:
    - 1 digital input (up to 3 digital inputs for motorized valve control version), and up to 3 digital outputs
    - Remote SV input, analog re-transmission output
    - Motorized valve control output
    - Current monitoring using CT
- Easy-to-see clear display and user-friendly interface
  - Wide viewing angle, high luminance white LED backlit LCD
  - Large PV display (with character height of 15.3 mm which is the highest in the market)
  - Easy-to-distinguish parameter display with screen numbers
  - Easy-to-identify 11 segment alphanumeric display
  - Digit select key for easier value-setting (5 keys)
- Most compact design in the market
  - Approx. 30% reduction in size compared to conventional models.  
(58 mm depth behind panel)

- A variety of functions extending the possibility of temperature controller
  - 64 steps ramp/soak function
  - 8 PID setting pallets, 8 SV pallets, zone PID facilitate frequent change of control conditions
  - Loader interface provided as standard (Power can be supplied via loader cable. Loader software is available from our HP for free of charge)
  - RS-485 communication (optional) capable of cooperative operation, programless communication

## SPECIFICATIONS

### 1. General specifications

#### Power supply:

100 V (-15%) to 240 V (+10%) AC, 50/60 Hz;  
24 V (±10%) DC/AC

#### Power consumption:

10 VA MAX. (100 to 240 V AC), 3 VA MAX. (24 V DC/AC)

#### Insulation resistance:

20 MΩ or more (at 500 V DC)

#### Withstand voltage:

Power source ↔ all terminals: 1500 V AC for 1 min  
Relay contact output ↔ all terminals: 1500 V AC for 1 min  
Between others 500 V AC for 1 min

### 2. Input section

#### 2.1 Process value input

##### Number of input:

1

##### Input setting:

Programmable scale

##### Input signal:

See Table 1

(Universal input: thermocouple, RTD, voltage, current)

##### Standard measurement range and input type:

See Table 1

**Indication accuracy (at Ta = 23°C):**

- Thermocouple input: either  $\pm 1^\circ\text{C} \pm 1$  digit or  $\pm 0.3\% \pm 1$  digit of indicated value, whichever is larger

\*except:

- Thermocouple B: 0 to 400°C: no accuracy assurance
- Thermocouple R: 0 to 500°C:  $\pm 3^\circ\text{C} \pm 1$  digit
- Thermocouples K, T, E, U, or N: -200 to -100°C:  
 $\pm 2^\circ\text{C} \pm 1$  digit

- RTD input:  $\pm 0.8^\circ\text{C} \pm 1$  digit or  $\pm 0.2\% \pm 1$  digit of indicated value, whichever is larger
- mV input, voltage input, current input:  $\pm 0.3\% \text{FS} \pm 1$  digit

**Temperature effect on sensitivity:**

$\pm 0.3\% \text{FS} / 10^\circ\text{C}$

**Indication resolution:**

See Table 1

**Input sampling rate:**

50 ms

**Input impedance:**

- Thermocouple, mV input: 1 M $\Omega$  or more
- Current input: 150  $\Omega$  or less (built-in diode)
- Voltage input: About 1 M $\Omega$

**Variation by signal source resistance:**

- Thermocouple, mV input:  $\pm 0.3\% \text{FS} \pm 1$  digit per 100  $\Omega$
- Voltage input:  $\pm 0.3\% \text{FS} \pm 1$  digit per 500  $\Omega$

**Allowable wiring resistance:**

RTD: 10  $\Omega$  or less (per wire)

**Allowable input voltage:**

- DC voltage input: within  $\pm 35\text{V}$
- Current input: within  $\pm 25$  mA
- Thermocouple, RTD, mV input: within  $\pm 5$  V

**Noise reduction ratio:**

- Normal mode: 40 dB (50/60 Hz)
- Common mode: 120 dB (50/60 Hz)
- Between input and power supply:  $\pm 1^\circ\text{C}$  at 220 V AC, 50/60 Hz

**Input correction:**

- User adjustment:  $\pm 50\% \text{FS}$  for each of zero and span point
- Process value shift:  $\pm 10\% \text{FS}$
- Input filter: 0.0 to 120.0 s  
(filter OFF if set at 0.0)
- Square root extraction: -0.1 to 105% (OFF if set to -0.1%)

**Overrange, underrange:**

Beyond range of -5 to 105% (accuracy not guaranteed between -5 and 0, and between 100 and 105%FS)

\*Pt (-200 to 850°C) input: out of the range between -2 to 105%

0 to 10 V DC input: out of the range between -2 to 105%  
Thermocouple E input: out of the range between -5 to 102%

**2.2 Remote SV input (optional)****Number of inputs:**

1

**Input signal:**

Voltage: 0 to 5 V DC / 1 to 5 V DC / 0 to 10 V DC,

Current: 0 to 20 mA DC / 4 to 20 mA DC (a 250 $\Omega$  resistor is required for current input)

**Input impedance:**

About 1 M $\Omega$

**Sampling rate:**

50 ms

**2.3 Current transformer (CT) input (optional)****Input type:**

- Single phase CT, 1 point
- For 1 A to 30 A: CTL-6-S-H
- For 20 A to 100 A: CTL-12-S36-8F

**Range of detected current:**

1 A to 100 A

**Detected current accuracy:**

Setpoint  $\pm 5\% \text{FS}$

**Detected current resolution:**

0.1 A

**ON time necessary for detection:**

300 ms MIN.

**2.4 Digital input (DI) (optional)****Number of points:**

Up to 1 (Up to 3 digital inputs for motorized valve control version)

**Specifications:**

No-voltage contact or transistor input

**Contact capacity:**

5 V DC, about 2 mA (per point)

**Input judgment:**

- ON voltage: 2 V DC or lower
- OFF voltage: 3 V DC or higher

**Sampling pulse width:**

50 ms MIN.

**Functions:**

Remote mode selection, SV changeover, control standby, AT startup, timer startup, alarm unlatch, program selection, start/stop/reset, PID switching (normal/reverse), etc.

**3. Output section****3.1 Control output****Number of points:**

Up to 2 (2 points: Heating/cooling control)

**Type:**

selected among (1) to (6) below

**(1) Relay contact output (SPST)**

- Proportional cycle: 1 to 150 sec
- Contact structure: SPST (single pole single throw)
- Contact capacity: 250 V AC/30 V DC, 3 A (resistive load)
- Minimum ON/OFF current: 10 mA (5 V DC)
- Mechanical life: 20 million operations MIN. (100 operations/min)
- Electrical life: 100,000 operations MIN. (rated load)

**(2) Relay contact output (SPDT)**

- Proportional cycle: 1 to 150 seconds
- Contact structure: SPDT (single pole double throw)
- Contact capacity: 250 V AC/30 V DC, 5 A (resistive load)
- Mechanical life: 50 million operations MIN. (100 operations/min)
- Electrical life: 100,000 operations MIN. (rated load)

**(3) SSR drive output**

- Proportional cycle: 1 to 150 s
- ON voltage: 12 V DC (between 10.7 and 13.2V DC)
- OFF voltage: 0.5 V DC or lower
- Maximum current: 20 mA DC
- Load resistance: 600  $\Omega$  MIN.

**(4) Current output (0 to 20 mA DC/4 to 20 mA DC)**

- Accuracy:  $\pm 5\% \text{FS}$
- Load resistance: 500  $\Omega$  MAX.

**(5) Voltage output (0 to 5 V DC/1 to 5 V DC/0 to 10 V DC/2 to 10 V DC)**

- Accuracy:  $\pm 5\% \text{FS}$
- Load resistance: 10 k $\Omega$  MIN.

- (6) Motorized valve control output
- Contact structure: 2 SPST contacts without interlock circuit
  - \*SPST: Single Pole Single Throw
  - Contact capacity: 250 V AC/30 V DC, 3A (resistive load)
  - Mechanical life: 20 million operations MIN. (100 operations/min)
  - Electrical life: 100,000 operations MIN. (rated load)

### 3.2 Alarm output (optional)

#### Number of outputs:

Relay contact output: Up to 3 (shared common)  
Up to 2 (independent common)

#### Output specifications:

Relay contact output  
Contact structure: SPST (single pole single throw)  
Contact capacity: 250 V AC/30 V DC, 1 A (resistive load)  
Minimum ON/OFF current: 10 mA (5 V DC)  
Mechanical life: 20 million operations MIN.  
(100 operations/min)  
Electrical life: 100,000 operations MIN. (rated load)

#### Output functions:

Alarm output (see "Alarm function"), main unit control mode output, program status output, control output 1 and 2, etc.

#### Output cycle:

100 ms

### 3.3 Re-transmission output (optional)

#### Number of points:

1

#### Type:

Current/voltage output (0 to 20 mA DC/4 to 20 mA DC/0 to 5 V DC/1 to 5 V DC/ 0 to 10 V DC/2 to 10 V DC)

- Guaranteed output range: 0 to 21.0 mA DC/0 to 10.5 V DC
- Accuracy:  $\pm 0.2\%$ FS ( $\pm 5\%$ FS at 1 mA or smaller)
- Resolution: 10,000 MIN.
- Load resistance: 500  $\Omega$  MAX. (current), 10 k $\Omega$  MIN. (voltage)

#### Output cycle:

100 ms

#### Output contents:

PV, SV, DV, MV

#### Additional function:

Scaling function

## 4. Indication/setting section

### 4.1 Display unit

#### Type:

LCD (with backlight)

#### Indication contents:

Process value indication: 11-segment, 4-digit [white]  
Setpoint indication: 11-segment, 4-digit [green]  
Screen No. indication: 7-segment, 3-digit [orange]  
Indication status: 23 indicator lamps

#### Luminance setting:

possible (4 steps)

### 4.2 Setting section

#### Type:

Sheet type keys (with emboss)

#### Number of keys:

5 keys

## 5. Control functions

### 5.1 Control types

#### ON/OFF control

#### PID control

- Dual control (heating/cooling)
- PID parameters determination: Auto tuning

#### Fuzzy PID control

- Dual control (heating/cooling)
- PID parameters determination: Auto tuning

#### Self tuning control

#### PID2 control

- Dual control (heating/cooling)
- PID parameters determination: Auto tuning

#### 2-degrees-of-freedom PID

- PID parameters determination: Auto tuning

#### Position proportional PID (servo) control without position feedback

- Full stroke time: 30 seconds MIN.

### 5.2 Control parameters

- Proportional band (P): 0.1 to 999.9%
- Integral time (I): 0 to 3200 s  
Integral time control invalidated when I = 0.
- Differential time (D): 0.0 to 999.9 s  
Differential time control invalidated when D = 0.
- Control cycle: 100 to 900 ms (in 100 ms), 1 to 99 s (in seconds)
- Anti-reset windup:  
0 to 100% of measurement range
- Hysteresis band: 50% of measurement range (at 2-position control only)
- Number of SV and PID combinations: 8 combinations.  
Changed by any of parameter setting, digital input, communication, user function keying, zone change.

### 5.3 Control mode

#### Mode type:

Auto, Manual, Remote

\* During 2-position control in Manual mode, 2-position manual operation with MV = 100% or 0% is operated.

#### Mode switching:

- Auto  $\leftrightarrow$  Manual: Balanceless·bumpless
- Auto/Manual  $\rightarrow$  Remote: Balance·bumpless
- Auto/Manual  $\leftarrow$  Remote: Balance·bumpless

## 6. Alarm function

### 6.1 Number of alarm setting points

3 points

### 6.2 Alarm type

Process value (upper limit/lower limit, absolute/deviation, range), main unit error, etc.  
(non-excitation, delay, latch, timer function option provided)

### 6.3 Heater current alarm function (optional)

\*Current detector (CT) is to be prepared separately (see page 7.)

#### Detectable range:

1 A to 100 A

#### Detected current resolution:

0.1 A

#### Setting resolution:

0.1 A

#### Hysteresis:

0.0 A to 100.0 A

**7. Communication function****7.1 RS-485 interface (optional)****Number of points:**

1 point

**Physical specifications:**

EIA-485

**Protocol:**

Modbus-RTU

**Communication method:**

Half duplex bit serial, Asynchronous communication

**Code type:**

Data length: 8 data bits. Parity: Odd, even, none.

**Communication rate:**

9600 bps, 19200 bps, 38.4 kbps, 115.2 kbps

**Connection status:**

Up to 32 units connectable including multidrop master function

**Communication distance:**

Up to 500 m (total connect extension)

**Additional functions:**

- Cooperative operation  
The function in which several temperature controllers (as slave devices) can be operated by a master temperature controller.
- Programless communication  
The function in which a temperature controller can communicate with a PLC without program.  
Supported PLCs: Mitsubishi PLC Q series  
Siemens PLC S7 series

**8. Data backup at power failure**

Memory protection: Protect by non-volatile memory

**9. Self-diagnosis**

Method: Program error supervision by watchdog timer

**10. Operation and storage conditions****Operating ambient temperature:**

-10 to 50°C

**Storage temperature:**

-20 to 60°C

**Operating/storage ambient humidity:**

90%RH MAX. (no condensing)

**Warm-up time:**

30 min MIN

**Vibration:**During transportation 9.8 m/s<sup>2</sup> (1G) or less**Impact:**During transportation: 294 m/s<sup>2</sup> (30G) or less**11. Structure****Mounting method:**

Panel mount

**External terminals:**

Screw terminals, M3

**Case: material:**

- ABS, PPO
- Non-combustibility grade: UL94V-0 equivalent
- Color: Black

**Protection structure:**

- Panel front side: IP66, NEMA-4X equivalent  
(When the panel is mounted using our genuine packing. Not water-proof if mounted closely together.)
- Body: IP20 equivalent (slits on top and bottom)
- Terminals: IP00 equivalent. Terminal cover can be mounted optionally.

**Dimensions:**

48 (W) × 48 (H) × 58 (D) mm

**Weight:**

approx. 100g

**12. User customize function****12.1 Program (ramp/soak) function****Number of program steps:**

- 64 steps x 1 pattern,
- 32 steps x 2 pattern,
- 16 steps x 4 pattern
- 8 steps x 8 pattern  
(1 step = 2 segments)

**Control option:**

- Operation control by digital input
- Status output by digital output

**Basic functions:**

- (1) Segment time can be set in "Hour, Minutes" or "Minutes, Seconds"
- (2) Guarantee soak
- (3) Repeat action
- (4) PV start
- (5) Delay start
- (6) Power restoring function

**Memory backup:**

EEPROM

**12.2 User functions**

Pressing the user key can perform Auto/Manual change, Standby ON/OFF change, local SV/remote SV change, ramp/soak change or other functions as assigned.

**12.3 Password function**

3-level password function

**13. Simple power-monitoring function and operating days alarm****13.1 Simple power-monitoring function**

- By connecting a current transformer (to be prepared separately), electric power consumption of a heater can be displayed.  
(Electric power is calculated with the fixed voltage value.)
- Current detector (CT) is to be prepared separately (see page 7.)
- Current detection range: 1 A to 100 A

**13.2 Operating days alarm**

- Displays the operating days and activates alarm output (optional) when it exceeds the setpoint.
- This function is useful for preventive maintenance because it let you know the appropriate time for maintenance work.

**14. Certification**

UL, C-UL, CSA

**15. EU Directive Compliance** 

LVD (2014/35/EU)

EN 61010-1

EN 61010-2-030

EMC (2014/30/EU)

EN 61326-1 (Table 2)

EN 55011 (Group 1 Class A)

EN 61000-3-2 (Class A)

EN 61000-3-3

RoHS (2011/65/EU)

EN 50581

**Table 1 Measurement range**

Input type		Code (PvT)	Measurement range [°C]	Minimum input increment [°C]
RTD	Pt100	PT1	0.0 to 150.0	0.1
		PT2	0.0 to 300.0	0.1
		PT3	0.0 to 500.0	0.1
		PT4	0.0 to 600.0	0.1
		PT5	-50.0 to 100.0	0.1
		PT6	-100.0 to 200.0	0.1
		PT7	-199.9 to 600.0	0.1
		PT8	-200 to 850	1
Thermocouple	J	J1	0.0 to 400.0	0.1
		J2	-20.0 to 400.0	0.1
		J3	0.0 to 800.0	0.1
		J4	-100 to 1000	1
	K	K1	0 to 400	0.1
		K2	-20.0 to 500.0	0.1
		K3	0.0 to 800.0	0.1
		K4	-200 to 1300	1
	R	R	0 to 1700	1
	B	B	0 to 1800	1
	S	S	0 to 1700	1
	T	T1	-199.9 to 200.0	0.1
		T2	-199.9 to 400.0	0.1
	E	E1	0.0 to 800.0	0.1
		E2	-150.0 to 800.0	0.1
		E3	-200 to 800	1
	L	L	-100 to 850	1
	U	U1	-199.9 to 400.0	0.1
		U2	-200 to 400	1
	N	N	-200 to 1300	1
W	W	0 to 2300	1	
PL-II	PL-2	0 to 1300	1	
DC voltage	0 to 5 V	0-5V	-1999 to 9999 (Scaling range)	-
	1 to 5 V	1-5V		
	0 to 10 V	0-10		
	2 to 10 V	2-10		
	0 to 100 mV	MV		
DC current	0 to 20 mA	0-20		
	4 to 20 mA	4-20		

\* Input signal, measurement range, and set value at the time of delivery are as follows:

Thermocouple K, Measurement range from 0 through 400°C, Set value 0°C.

Switching the input signal among thermocouple, RTD, current, and voltage is available by key operation on the front panel.

## CODE SYMBOLS

<48 x 48mm size>

Standard type

Digit	Specifications	Note	4	5	6	7	8	9	10	11	12	13
4	<Front panel size W × H> 48 × 48mm		4	A			2				0	0
5	–			A								
6	<Control output 1> Relay contact (SPST) Relay contact (SPDT) SSR drive output Current output Voltage output	Note1 Note2		A	B C E P							
7	<Control output 2> None Relay contact (SPST) SSR drive output Current output Voltage output Re-transmission output (current) Re-transmission output (voltage)					Y A C E P R S						
8	<Revision code>						2					
9	<Alarm output> None 1 point 2 points 3 points 2 points (independent common)							0 1 F M J				
10	<Power supply voltage/instruction manual> 100 to 240 V AC, Japanese & English 100 to 240 V AC, English 100 to 240 V AC, Chinese & English 24 V AC/DC, Japanese & English 24 V AC/DC, English 24 V AC/DC, Chinese & English							Y V W A B D				
11	<Option> None RS-485 Communication Digital input (DI1) RS-485 communication + Digital input (DI1) RS-485 communication + Remote SV input RS-485 Communication + CT input	Note3 Note4								1 M S V K J		
12	–										0	0
13	–										0	0

Note 1: The 6th code "A" is incompatible with the 7th codes "C", "E", and "P".  
If you want to select the 6th code "A" and the 7th code "R" or "S" which is non-standard version, enter "02" in the 12th and 13th codes, as follows:

PXF4AA 

R
S

 2-□□□02

Note 2: The 6th code "B" is incompatible with the 7th codes "C", "E", "P", "R", and "S".  
Note 3: When using the current input for the remote SV input, add a 250-ohm resistor to the input terminal.  
Note 4: When using the CT input as a heater burnout alarm, add one alarm output for it in the 9th code.

## SCOPE OF DELIVERY

- Controller × 1
- Instruction manual × 1
- Panel mounting frame × 1
- Watertight packing × 1

<48 x 48mm size>

Motorized valve control type

Digit	Specifications	Note	4	5	6	7	8	9	10	11	12	13
4	<Front panel size W × H> 48 × 48mm		4	A	T	Y	2					
5	—											
6	<Control output 1> Motorized valve control output											
7	<Control output 2> None											
8	<Revision code>											
9	<Alarm output> None 1 point 2 points 2 points (independent common)								0 1 F J			
10	<Power supply voltage/instruction manual> 100 to 240 V AC, Japanese & English 100 to 240 V AC, English 100 to 240 V AC, Chinese & English 24 V AC/DC, Japanese & English 24 V AC/DC, English 24 V AC/DC, Chinese & English								Y V W A B D			
11	<Option> None Digital input (DI 1, 2, 3) RS-485 communication + Digital input (DI1)									1 D V		
12	—											0
13	—											0

## OPTIONAL ITEMS

Instruction manual for RS-485 communication function (MODBUS)	Type: INP-TN5A2227
Current detector (CT) 1 to 30 A 20 to 100 A	Type: ZOZ*CCTL-6-S-H Type: ZOZ*CCTL-12-S36-8
Terminal cover	Type: ZZPPXR1-A230
Parameter loader interface cable	Type: ZZP*IQ501923C3
Shunt resistor (250Ω ± 0.1%)	Type: ZZPPXR1-A190

Current detector (CT)

• Specification : 1 to 30 A

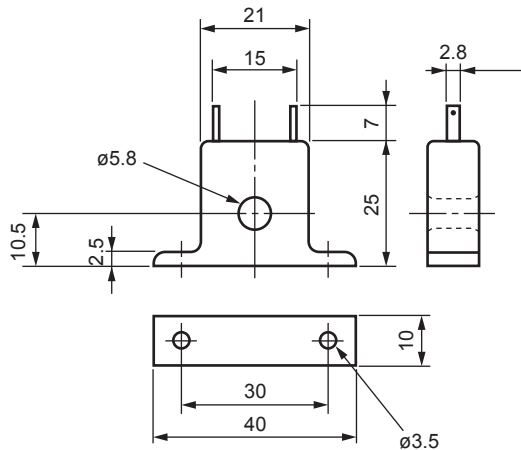

• Specification : 20 to 100 A

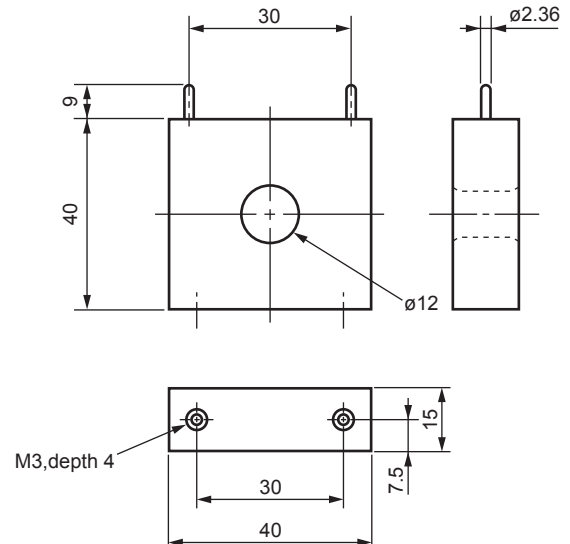

Note 1) Detection is available only for single phase heater.

Note 2) Unusable for heater control by thyristor phase angle control.

# PXF4-2

Panel mounting adapter for replacement from PXR7 to PXF4 (Type: ZZP\*TQ502732C1)

## Outline diagram

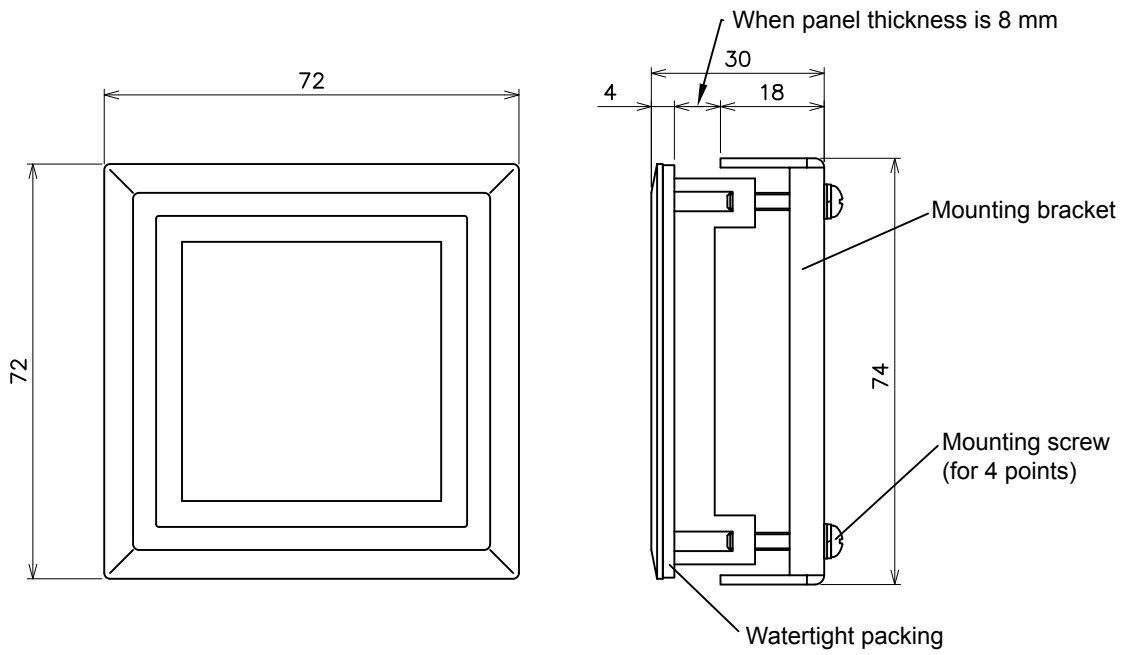

## How to install PXF4 with the adapter

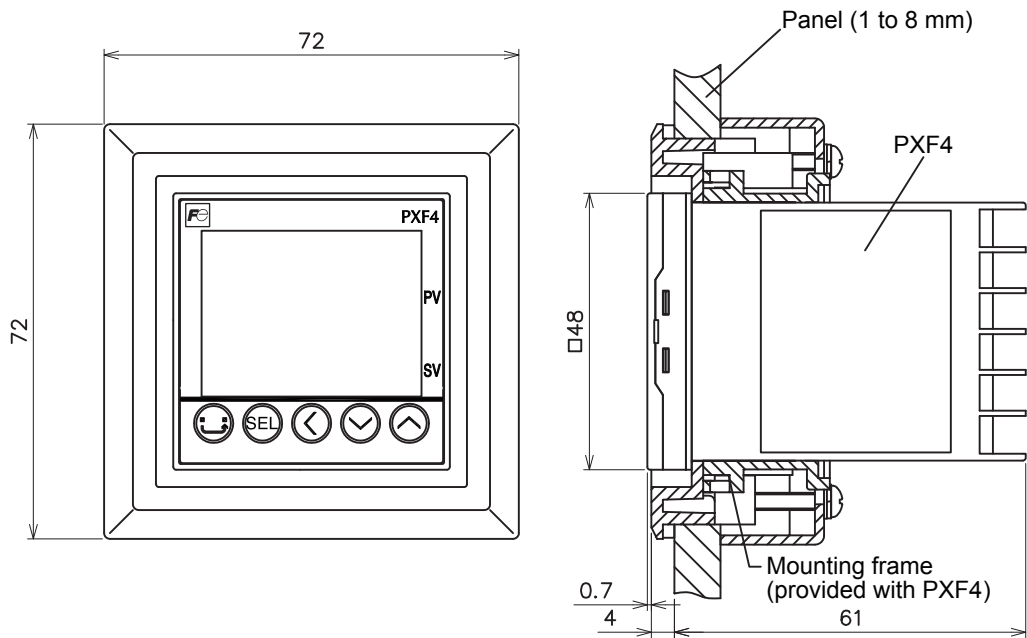



## OUTLINE DIAGRAM (Unit : mm)

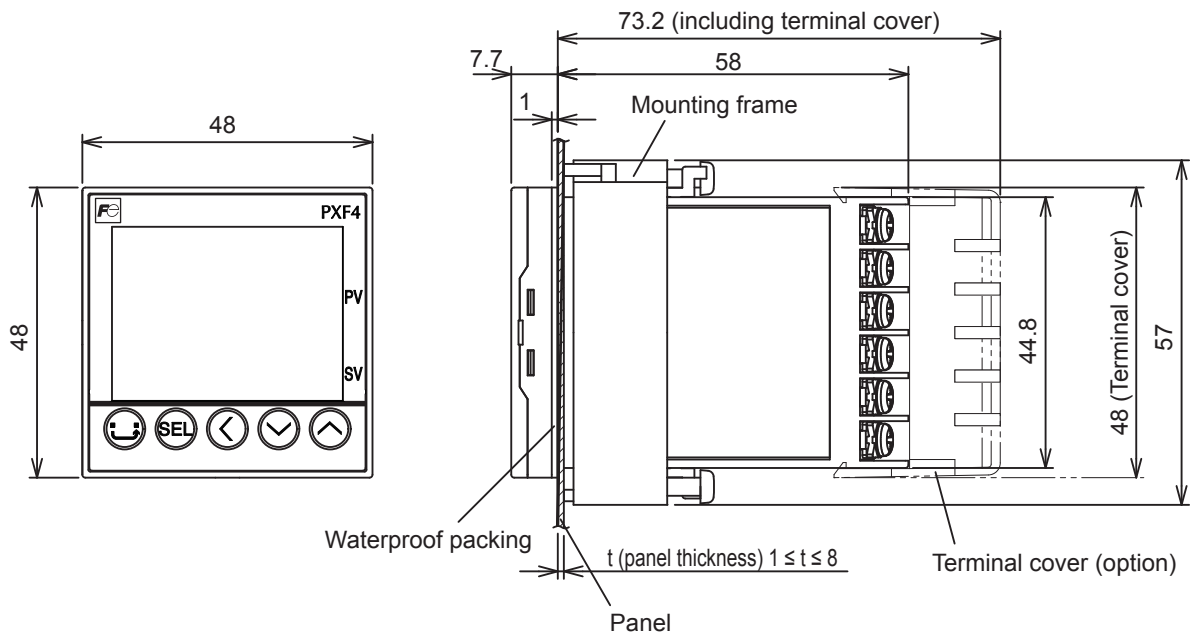

## PANEL CUTOUT SIZE (Unit : mm)

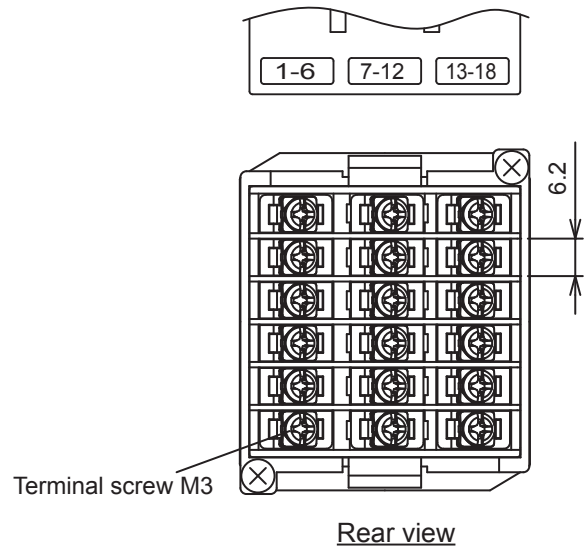
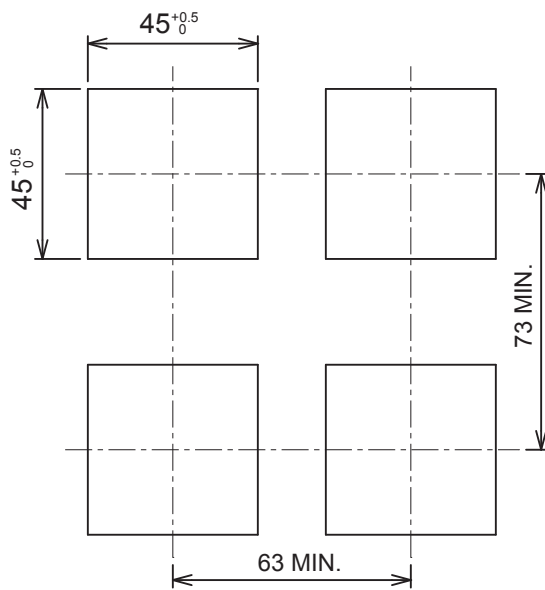

Terminal block is not attached to unused terminals (terminal 7 to 12) according to the model.

### Side stick mounting (n units)

Waterproof is not available in stick mounting.

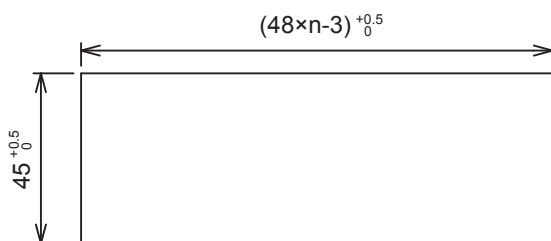

# TERMINAL ALLOCATION

## Standard type

Standard type

Control output 1	Relay output (SPST)	Relay output (SPDT)	SSR	Current	Voltage	Relay output (SPST)	Relay output (SPDT)	SSR	Current	Voltage
Control output 2	None	None	None	None	None	Relay output (SPST)	Relay output (SPDT)	Relay output (SPST)	Relay output (SPST)	Relay output (SPST)

Control output 1	SSR	Current	Voltage	SSR	Current	Voltage	SSR	Current	Voltage
Control output 2	SSR	SSR	SSR	Current or re-transmission output (current)	Current or re-transmission output (current)	Current or re-transmission output (current)	Voltage or re-transmission output (voltage)	Voltage or re-transmission output (voltage)	Voltage or re-transmission output (voltage)
				or re-transmission output	or re-transmission output	or re-transmission output	or re-transmission output	or re-transmission output	or re-transmission output

### Alarm output

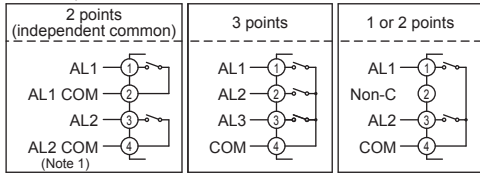

Note 1: Power supplies for AL1 and AL2 must be of the same type, either AC or DC.

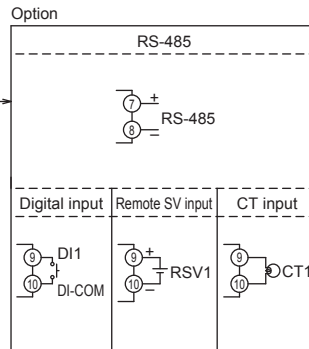
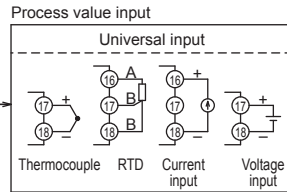
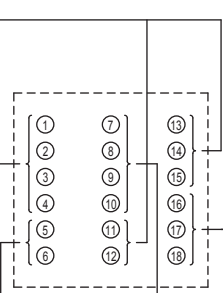
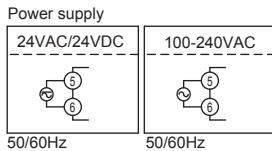

# Motorized valve control type

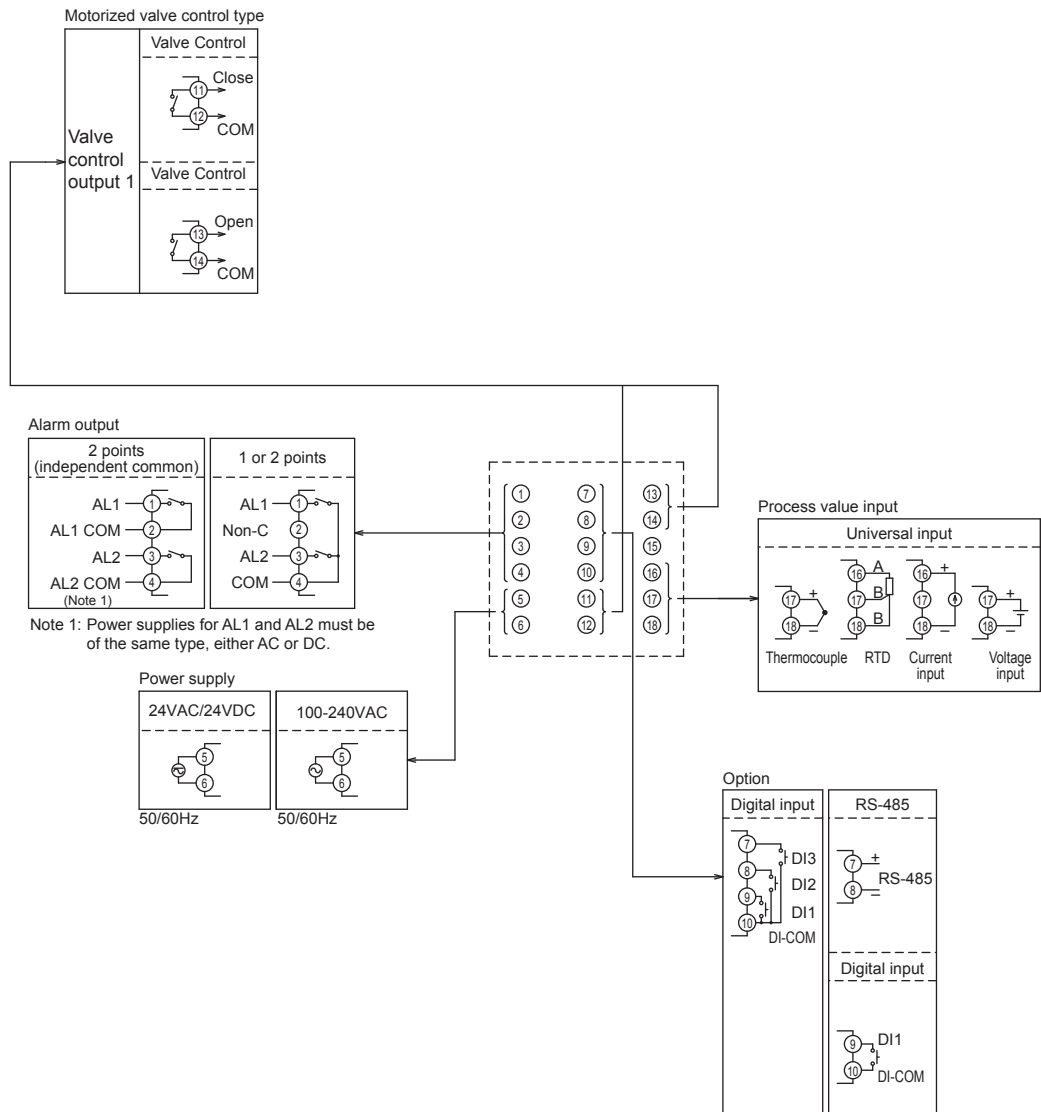

## INSULATION BLOCK DIAGRAM

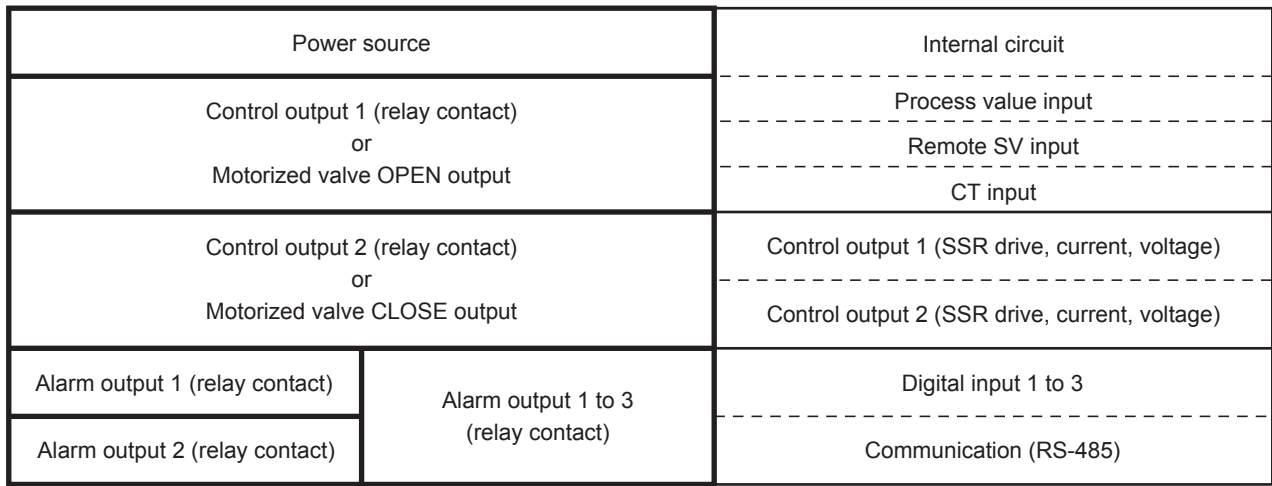

- When the 9th code is "J"  
AL 1 and 2:  
independent common
- When the 9th code is other than "J"  
AL 1 to 3:  
shared common

- : Basic insulation
- : Functional insulation
- - - - - : No insulation

Information in this catalog is subject to change without notice.  
Read the instruction manuals thoroughly before using the products.



Gate City Ohsaki, East Tower, 11-2, Osaki 1-chome, Shinagawa-ku, Tokyo 141-0032, Japan  
Phone: +81-3-5435-7111  
www.fujielectric.com  
www.fujielectric.com/products/instruments/