

ACCURACY

0 to 20% of Range: $\pm(0.02\%$ of Full Scale)
 20% to 110% of Range: $\pm(0.1\%$ of Reading)
 Vacuum: $\pm(0.25\%$ of Full Scale*)
 * Full Scale = -14.5 psig

Includes all effects of linearity, hysteresis, repeatability, temperature, and stability for one year.

All models indicate vacuum, but vacuum specification applies to 15 psi, 30 psi, 100 psi, and 300 psi models only.

Not recommended for continuous use below -14.5 psi. Refer to [XP2i-DP data sheet](#) for gauges that are intended for continuous high vacuum use.

OPERATING TEMPERATURE

Temperature Range: **-10 to 50° C (14 to 122° F)**

Non-condensing. No change in accuracy over operating temperature range. Gauge must be zeroed to achieve rated specification.

DISPLAY

Screen: **5.5 digits, 16.9 mm (0.67") high**
 Display Rate: **4 readings/second (standard)**
8 readings/second (PSV mode)

LCD readable in sunlight with bright backlight.

PSV mode is intended for Pressure Safety Valve testing, and requires software to enable. (ConfigXP is a free download from [XP2i.com](#).)

POWER

3 x AA: **1500 hours, typical**
 Ultra Low Power: **> 1 year, typical****

Uses 3 alkaline AA (LR6) batteries. Use of backlight and/or RS232 reduces operating time.

Optional AC power supply available.
WARNING: Do not use AC power supply in hazardous locations.

**20 minute recording interval or greater in LT5 mode.

DATA/COMMUNICATION

Digital Interface: **RS232, DB-9F**

Free Labview® drivers and programming instructions are available for download from website.

WARNING: Do not use RS232 in hazardous locations.

DATALOGGING

Capacity: **32000 data points**
 Storage Type: **Non-volatile flash memory**
 Minimum Interval: **1 second**
 Maximum Interval: **18 hours**
 Min. Event Duration: **250 mS*****

DataLoggerXP Firmware Update may be purchased at time of order, or an Upgrade Package may be purchased afterward.

Software available for download from our website. Compatible with 32 & 64 bit Windows 7, Vista, and XP (32 bit only). Produces csv files, or uses Excel template files (samples included) to automatically format and graph data.

*** Logging Type - Average with Peaks.

U.S. PATENT D612277

ALL DIMENSIONS IN MM (IN)

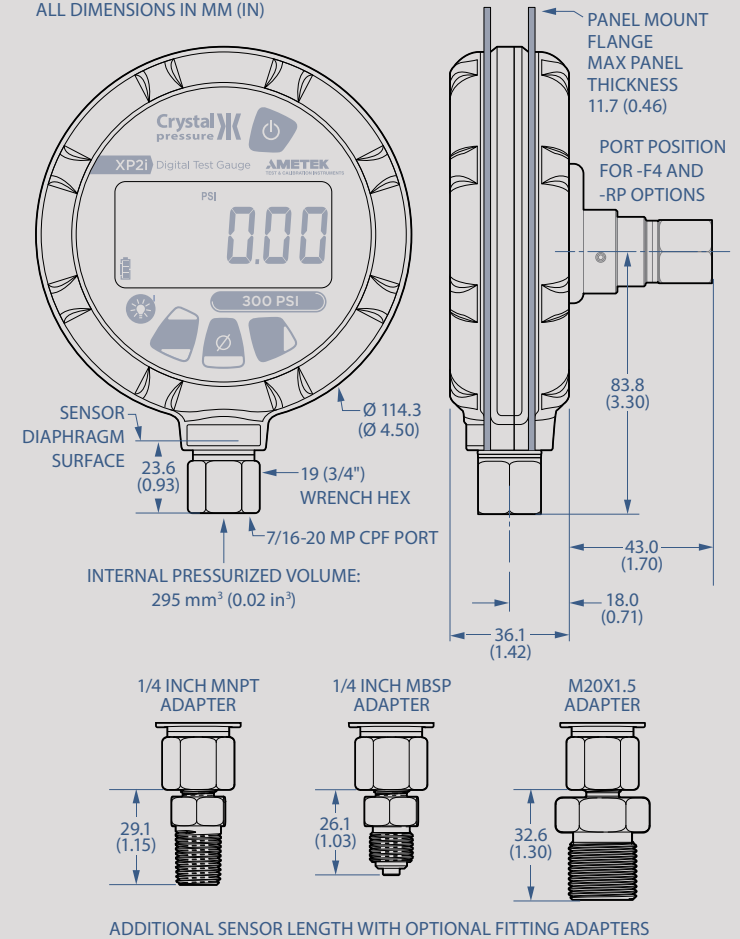

ENCLOSURE

Weight: 562 g (19.8 oz)	<i>Weight includes batteries.</i>
Rating: IP67	<i>Submersible to 1 m for 30 minutes [IEC 60529].</i>
Housing: Diecast aluminum	<i>Nickel plating over low copper, marine grade aluminum.</i>
Keypad and Labels: UV Resistant Polyester	<i>LCD protected from impact damage by 1.5 mm (0.06") thick polycarbonate lens under polyester window.</i>
	<i>Skydrol® compatible.</i>

SENSOR

Wetted Materials: (WRENCH TIGHT) 316 stainless steel	<i>All welded, with a permanently filled diaphragm seal.</i>
(FINGER TIGHT) 316 stainless steel and Viton® (internal o-ring)	<i>Metal to metal cone seal; O-ring can be removed if necessary.</i>
Diaphragm Seal Fluid: Dow Corning® 200	<i>Optional connection on back.</i>
Connection: Crystal CPF Female	<i>1/4" male NPT adapter included unless BSP, M20, or 15KPSI is specified.</i>
	<i>1/4" medium pressure tube system compatible with HiP LM4 and LF4 Series, Autoclave Engr SF250CX Male and Female Series.</i>

STORAGE TEMPERATURE

Temperature Range: -40 to 75° C (-40 to 167° F)	<i>Batteries should be removed if stored for more than one month.</i>
--	---

SPECIAL FEATURES

The following requires the use of our free [ConfigXP](#) software

- User Defined Unit: **Allows the user to define and display any pressure units not included, or to use the gauge to display force, level, or other pressure related parameters. Reduce or increase displayed resolution.**
- PSV Mode: **Intended for pressure safety valve / burst disk testing. 8 readings per second. Captures point at which valve opens, as well as reset pressure.**
- Averaging: **Smooths unsteady readings (1 to 10 samples).**
- Remove: **Unwanted pressure units from Units button.**
- Disable: **Peak pressure button.**
- Limit or Disable: **Zero button.**
- Password Protect: **Changes to configuration or calibration factor(s).**
 - Save: **Configuration to a file.**
 - Copy: **Configuration can be copied to other gauges.**

XP2i Pressure Gauge **psi**

CERTIFICATIONS



**II 1G Ex ia IIC T4/T3 Ga
FTZU 12 ATEX 0048X**

This product conforms to:

EN 60079-0: 2009 | EN 60079-11: 2012 | EN 60079-26: 2007



**Ex ia IIC T4/T3 Ga
IECEx FTZU 12.0009X**

This product conforms to:

IEC 60079-0: 2011 | IEC 60079-11: 2011-06 | IEC 60079-26: 2006



Intrinsically Safe and Non-incendive for Hazardous Locations: Class I, Division 1, Groups A, B, C and D, Temperature Code T4 or T3C.



XP2i complies with the Electromagnetic Compatibility and the Pressure Equipment Directives. Refer to the EC Declaration of Conformity for specific details.



The instrument was tested against **AS/NZS 3584**, C-tick EMC/EMI requirements.



XP2i is approved for use as a portable test instrument for Marine use and complies with Det Norsjke Veritas' Rules for Classification of Ships, High Speed & Light Craft and Offshore Standards.

RANGE & RESOLUTION TABLE

P/N	Range (psi)	Over-pressure	Display Resolution									
			psi	in H ₂ O	in Hg	mm Hg	mm H ₂ O	kg/cm ²	bar	mbar	kPa	MPa
15PSI	15	6.5 x	0.001	0.01	0.001	0.01	1	0.0001	0.0001	0.1	0.01	0.00001
30PSI	30	3.0 x	0.001	0.01	0.001	0.1	1	0.0001	0.0001	0.1	0.01	0.00001
100PSI	100	2.0 x	0.01	0.1	0.01	0.1	1	0.0001	0.0001	0.1	0.01	0.00001
300PSI	300	2.0 x	0.01	0.1	0.01	1		0.001	0.001	1	0.1	0.0001
500PSI	500	2.0 x	0.01	1	0.1	1		0.001	0.001	1	0.1	0.0001
1KPSI	1000	2.0 x	0.1		0.1			0.001	0.001		0.1	0.0001
2KPSI	2000	2.0 x	0.1		0.1			0.01	0.01		1	0.001
3KPSI	3000	1.5 x	0.1		0.1			0.01	0.01		1	0.001
5KPSI	5000	1.5 x	0.1		1			0.01	0.01		1	0.001
10KPSI	10000	1.5 x	1					0.01	0.01		1	0.001
15KPSI	15000	1.3 x	1					0.01	0.01		1	0.001

ORDERING INFORMATION

P/N	Model	Adapter: Type	Connection: Location	Panel Mount?	Data-logging?
_____	XP2i	_____	_____	_____	_____
Standard:	NPT: (omit)	Bottom: (omit)	No: (omit)	No: (omit)	
Options:	G 1/4 B: -BSP	Back: -RP	Yes: -F4	Yes: -DL	
	M20x1.5: -M20	"omit" for -F4 panel mount	Includes -RP option		

SAMPLE PART NUMBERS

300PSIXP2I300 psi standard gauge, with a 1/4" NPT pressure fitting
 500PSIXP2I-BSP500 psi gauge, with a 1/4" BSP pressure fitting

Note: The 15KPSI gauge is available only with the CPF fitting.

ACCESSORIES



Protective Boot P/N 3696

Protect your XP2i even more from harsh environments with our form fitting chemical resistant thermoplastic boot (Skydrol fluid compatible).

AC Adapter Kit P/N 2984

For continuous use applications without battery replacement concern. Input voltage: 100 - 240V, 50-60 Hz. Includes all available international plugs. (Not for use in hazardous locations.)

COMPLIMENTARY PRODUCTS

Crystal Engineering offers a wide range of products that work with the XP2i:

- [Fittings that connect without tools, safely and without leaks](#)
- [Lightweight, super flexible high pressure hoses](#)
- [Complete Calibration Kits](#)
- [Pneumatic hand pumps](#)
- [Hydraulic hand pumps](#)
- [Portable pressure comparators](#)
- [Software, for the quickest way to calibrate pressure transmitters and gauges](#)

Autoclave Engineers Fluid Components is a division of Snap-tite, Inc.
 Dow Corning is a registered trademark of Dow Corning Corporation.
 HIP is High Pressure Equipment Company.
 Viton is a registered trademark of DuPont Performance Elastomers.